

TROEYE

Highly accurate
flow measurement
for clean and air
bubbles liquids

T2307

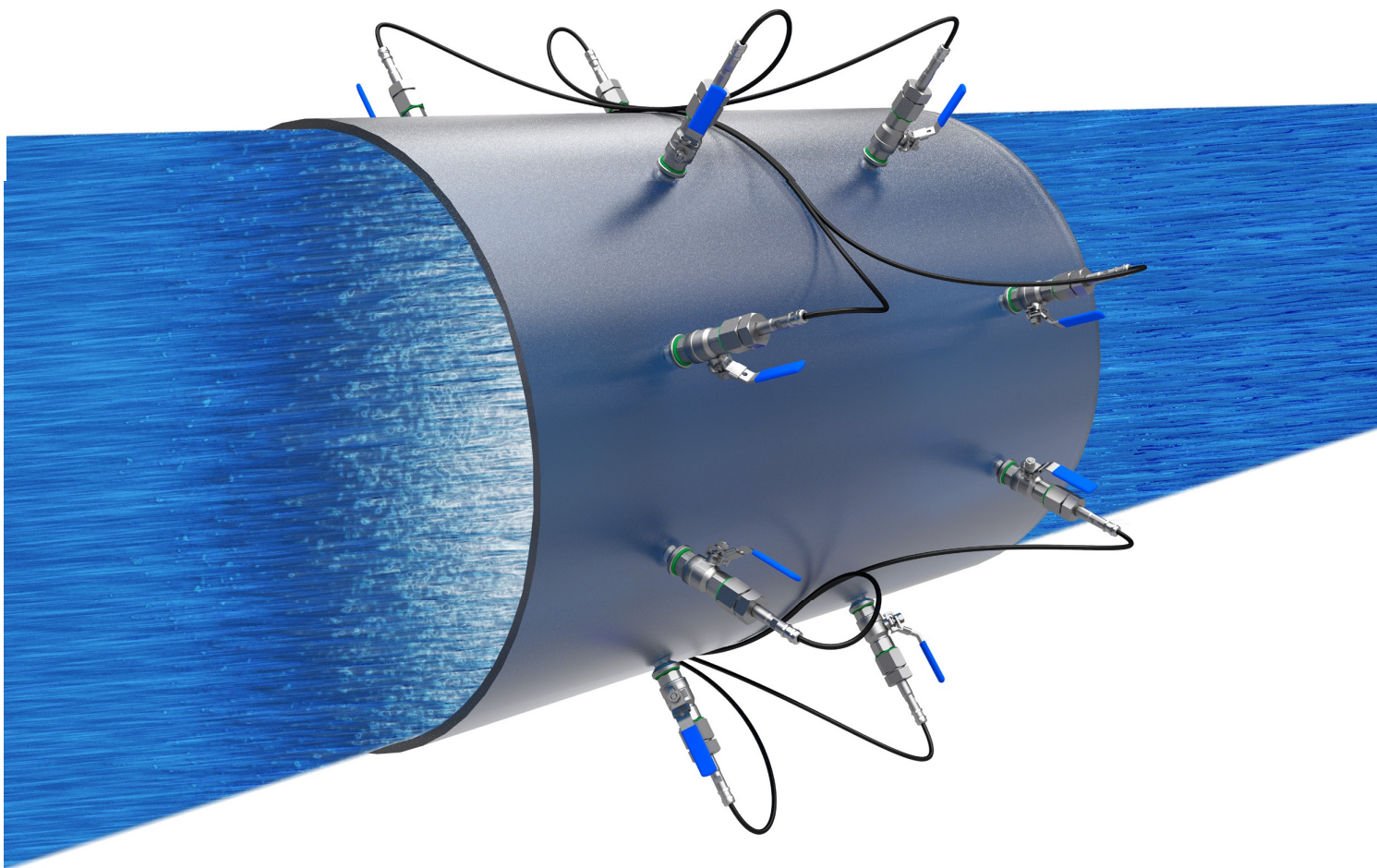



Application

Flow measurements are very often mandatory in the area of **water supply** and industry. Quite frequently the pipe systems are complex and contain valves and pumps. Additionally, there are space constraints, leading to difficulties in installing flowmeters at a recommended „optimum“ location, which is defined by a minimum distance upstream or downstream of known disturbances like an elbow or pump where a fully developed velocity profile is present. ReVision is able to increase your profitability with exceptional repeatability and linearity throughout the flow range. Due to the **patented** velocity profile compensation no flow straightener is needed and no on-site calibration is required.

ReVision is used for **highly accurate flow measurements in water distribution networks and hydro power plants**. The system is based on the well established acoustic transit-time principle. The digital signal processing allows detection of even the smallest time differences, i.e. even the smallest amounts are being determined accurately. Common installation effects e.g. after an 90° elbow are taken into account by patented corrections of the disturbed velocity profiles. No more need for the famous long straight runs in front of and after the flowmeter. Installation of a flow straightener is no longer necessary saving you time and money.

Advantages

- » Highly accurate flow measurements
- » No on-site calibration needed
- » No flow straightener needed
U0/D0
- » Patented velocity profile correction
- » certified by independent test centers
- » fully integrated metering solution



Specifications

Acoustic Paths:	2 - 16 transducer arranged in max. 5 planes, crossed bi-directional
Flow:	bi-directional
Accuracy:	up to $\pm 0,05\%$ with 16 transducer
Range:	0 to ± 20 m/s
Repeatability:	$< \pm 0,2\%$
Zero Stability:	< 1 mm/s
Pressure Range:	PN6, PN10, PN16
Communication:	RS-485, MODBUS, WLAN, GSM/GPRS Ethernet 10/100 Mbps
Inputs:	max. 4 x 4-20 mA, 2 x digital
Outputs:	max. 4 x 4-20 mA 2 x Pulse, 4x Relay
Power Supply:	85-260 V _{AC} (48-60 Hz) or 9-36 V _{DC}
Enclosure:	ABS, wall mounted

Concept

Space constraints and/or appropriate application configurations lead to complex industrial pipe flows which contain elbows, tees and/or other disturbing and non-uniform elements. This leads to difficulties in installing flow meters at a recommended "optimum" location, which is defined by a minimum distance upstream or downstream of known disturbances like an elbow or pump where a fully developed velocity profile is present. Even with multiple flow sensors, there may still be a significant error which is known as the profile factor.

During commissioning, the installation condition is entered into the device (e.g. 2 DN after a 90° elbow). During the following measuring operation, the various measuring planes capture the disturbed velocity profile. Finally, the integration of the volume flow is supported by numerically simulated weighting factors that are based on the parameterized installation conditions.

The high measuring accuracy has been certified by independent test centers.

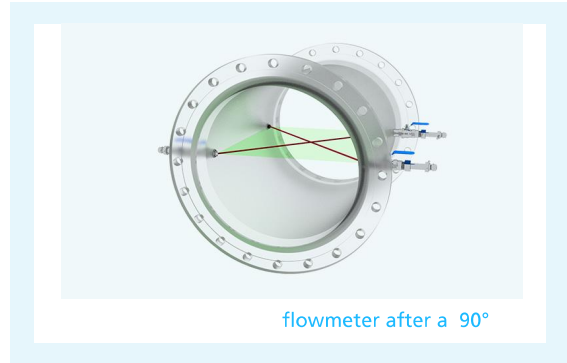

Flow meters are also sensitive to velocity profiles where there is a large rotational component (swirl). Swirl is normally generated by two or more out of plane changes in flow direction (e.g. one elbow/tee that goes from vertical to horizontal followed by an elbow/tee that changes the direction of flow in the horizontal plane). Swirl is present to some extent in almost every application and can generate significant transverse velocity components plus it takes a long distance to dissipate. If the swirl is not centred, it can cause significant errors. Thanks to the predetermined conduit configuration parameters and correction factors, the flow meter measurement accuracy is kept when asymmetric profiles and swirls are present in the pipe.

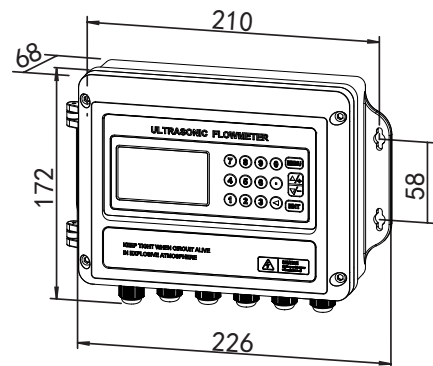
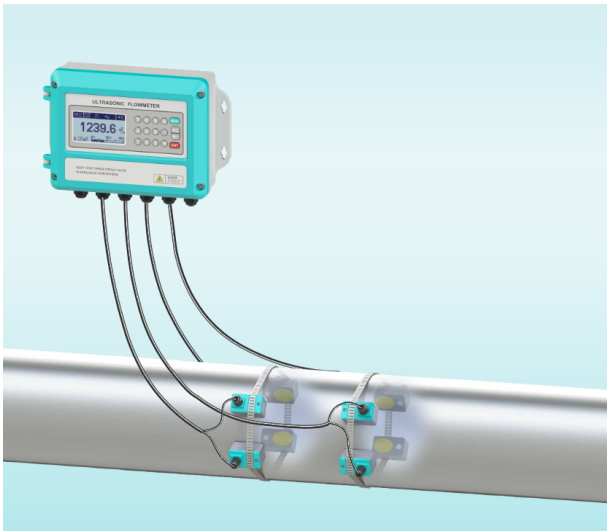

CROEYE Doppler and Transit Time Insertion Ultrasonic Flow Meter :

NOT:

- It is suitable for pipe sizes ranging from 65 to 4000mm
- the simultaneously ability to measure 'clean and dirty fluid or bubble fluids
- A wide range of flow measurement, high flow rate can reach 12m/s
- High-temperature transducer is suitable to liquids of -35 ~ 150
- Do not need to shut down the pipe flow when installing the transducers
- User-friendly configuration

Technical Data

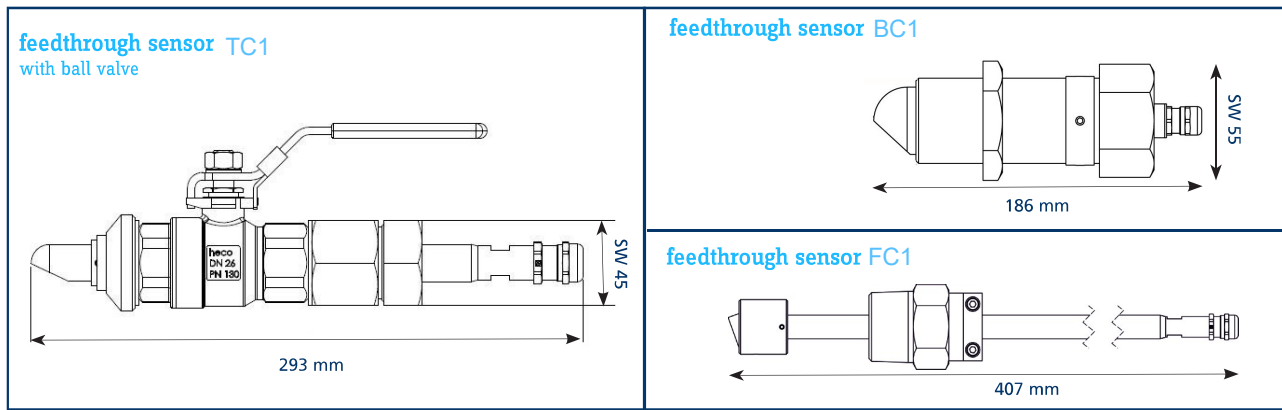

Wetted sensors



Frequency:	1 MHz	1 MHz	120 kHz / 1 MHz
Beam Width:	5° (-3dB)	10° (-3dB)	10° (-3dB)
Configuration:	IEC41 / ASMEPTC 18	n.a	IEC41 / ASMEPTC 18
Pipe Diameter:	0,1 m to 2 m	0,1 m to 4 m	0,3 m to 10 m (120° kHz) 0,3 m to 5 m (1 MHz)
Mounting:	welding socket or thread		
Pressure Rate:	20 bar *)	20 bar *)	60 bar *)
Material:	stainless steel	stainless steel, brass	stainless steel
Cable:	twisted pair with shield		
Operating Temp.:	0° to 40°C		
Dimensions:	Ø 1" Length: 293 mm	Ø 1 1/2" Length: 407 mm	Ø 1 1/2" Length: 186 mm
Installation:	incl. fixing device ball valve and welding socket	to be used in combination with 1 1/2" ball valve and NPT inner thread	
	Designed to allow removal of the entire transducer for repair, replacement or cleaning without the need to dewater the pipe		Removal of the transducer for repair, replacement or cleaning by means of a special jacking tool.
	Pipe needs to be dewatered only for the time of initial installation.		



UK : Flat 9 Queen Elizabeth House, 50 Queens Road, Weybridge, KT13 0AZ, London-UK

Email : info@trodeks.com

www.Trodeks.com